



# Wrangler® 2730/3330 DB

27 and 33-Inch Automatic Scrubbers



With the high performance Wrangler 2730 and 3330 DB, cleaning large areas has never been easier. These rugged and maneuverable autoscrubbers are unsurpassed for cleaning power, productivity, and dependability.

- The large 30-gallon solution tank and oversized recovery tank mean fewer refills, saving time and labor dollars.
- Variable speed wheel-drive, in both forward and reverse, provides exceptional maneuverability. It also allows the operator to match the machine's working speed to a comfortable pace, reducing fatigue.
- Two 0.75 HP brush motors and a powerful 0.75 HP vacuum motor combine with up to 200 pounds of brush pressure to handle heavy scrub jobs with ease.
- The high-frequency, "smart" on-board battery charger uses a temperature sensor to maximize charging efficiency.
- Available in both 27-inch and 33-inch scrub paths, these Wranglers are cost-savers for large areas up to 90,000 square feet.
- Optional Auto-Fill Battery Watering System and optional Low-Water Battery Alarm are available to help assure long battery life.

**NSS Enterprises, Inc.**  
3115 Frenchmens Road  
Toledo, Ohio 43607-2958  
USA  
[www.nss.com](http://www.nss.com)



Printed on Green Seal® certified paper that contains 30% recycled post-consumer fiber.

# Wrangler 2730/3330 DB Specifications

## Brush/Pad

2730	27 in (69 cm)
3330	33 in (84 cm)

## Pad Drivers

2730	Two 14 in (36 cm) poly back tufted
3330	Two 17 in (43 cm) poly back tufted

## Brush Motors

Type	36V, 2 permanent magnet, gear motors
HP	0.75 HP each
Speed	200 RPM
Pressure	100 lbs (45 kg), 200 lbs (91 kg)

## Vacuum Motor

Type	36V, 3-stage, bypass tang. discharge
HP	0.75 HP
CFM	73 (2 m <sup>3</sup> )
Waterlift	70 in (179 cm)

**Batteries** Six 6V, 235 or 350 AH (3.5 - 4.5 hours)

## Drive Motor

Type	36V permanent magnet
HP	0.5 HP
Drive System	Roller chain and sprockets
Speed	Variable; forward 0-240 ft/min (0-73 m/min), reverse 0-170 ft/min (0-52 m/min)
Wheel	10 in (25 cm) x 4 in (10 cm) tread

## Construction

Tank	Rotocast Polyethylene, 30 gal (114 L) solution, 32 gal (125 L) recovery
Frame	7-gage steel
Casters	Two 6 in (15 cm) mounted on rubber shock absorber

## Switches & Controls

Adjustable manual valve control with automatic solution shut-off in neutral; emergency stop button; brush pressure adjustment lever; vacuum and brush switches

## Squeegee

32 in (81 cm), 38 in (97 cm), swing-type, adjustable, Linatex blades, curved squeegee available

## Sound Level

66 dBA @ operator

## Dimensions

Height	42 in (107 cm)
Skirt Width 2730	30 in (76 cm)
Skirt Width 3330	35.5 in (90 cm)
Body Width	25.5 in (65 cm)
Length 2730	64 in (163 cm)
Length 3330	66 in (168 cm)

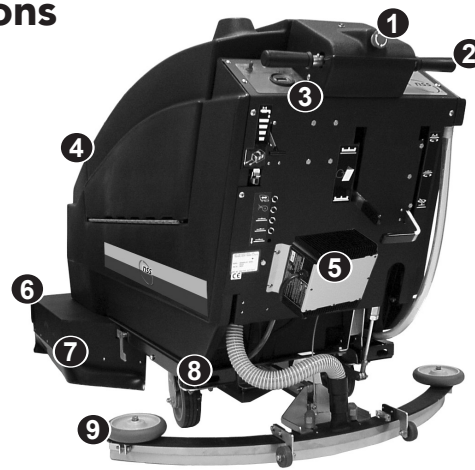

**DO NO HARM™**

Adjustable water flow helps conserve water use.

The frame is made from recycled steel, the batteries from recycled materials; and both are recyclable.

- Emergency stop master switch protects the operator
- Ergonomic handle grips and a torsion spring throttle make it easy to modulate working speed
- Hour meter tracks scheduled maintenance intervals.
- The recovery tank holds 33 gallons, extending runtime and increasing productivity.
- The on-board battery charger provides the convenience of charging batteries anytime.
- Optional low profile side skirt provides clearance under counters
- Side skirts can be mounted upside down for transport.
- 7-gage steel frame provides a solid foundation.
- Large bumper wheels reduce the possibility of squeegee damage.

## Weight

Machine 235 AH	864 lbs (392 kg)
Machine 350 AH	1,110 lbs (504 kg)
Shipping 235 AH	990 lbs (449 kg)
Shipping 350 AH	1,195 lbs (543 kg)

**Shipping Class** 70

## Warranty

3 year limited, 10 years on poly parts

## Productivity

Theoretical 2730	27,027 sq ft per hour (2,511 m <sup>2</sup> )
Theoretical 3330	32,872 sq ft per hour (3,054 m <sup>2</sup> )
Practical 2730	12,526 sq ft per hour (1,164 m <sup>2</sup> )
Practical 3330	15,301 sq ft per hour (1,422 m <sup>2</sup> )



**NSS Enterprises, Inc.**  
3115 Frenchmens Road  
Toledo, OH 43607-2958  
USA

P: (800) 677-1663  
F: (419) 531-3761

mailus@nss.com  
www.nss.com

Specifications subject to change without notice.

DISTRIBUTED BY